



European Technical Assessment

ETA-08/0173
of 23/05/2014

I GENERAL PART

TECHNICAL ASSESSMENT BODY ISSUING THE ETA AND DESIGNATED ACCORDING TO ARTICLE 29 OF THE REGULATION (EU) NO 305/2011

VTT EXPERT SERVICES LTD

TRADE NAME OF THE CONSTRUCTION PRODUCT

SORMAT THROUGH BOLTS S-KA, S-KAK, S-KAH, AND S-KAH HCR

PRODUCT FAMILY TO WHICH THE CONSTRUCTION PRODUCT BELONGS

TORQUE CONTROLLED EXPANSION ANCHORS OF SIZES M8, M10, M12 AND M16 FOR USE IN CONCRETE

MANUFACTURER

SORMAT OY
HARJUTIE 5
FIN-21290 RUSKO
FINLAND

www.sormat.fi

MANUFACTURING PLANT

SORMAT PLANT 1

THIS EUROPEAN TECHNICAL ASSESSMENT CONTAINS

14 PAGES INCLUDING 8 ANNEXES WHICH FORM AN INTEGRAL PART OF THIS ASSESSMENT

THIS EUROPEAN TECHNICAL ASSESSMENT IS ISSUED IN ACCORDANCE WITH REGULATION (EU) NO 305/2011, ON THE BASIS OF

GUIDELINES FOR EUROPEAN TECHNICAL APPROVAL ETAG 001 METAL ANCHORS FOR USE IN CONCRETE PART 1 AND PART 2, APRIL 2013, USED AS EUROPEAN ASSESSMENT DOCUMENT (EAD).

THIS VERSION REPLACES

EUROPEAN TECHNICAL APPROVAL
ETA-08/0173
From 5.6. 2013 to 4.5.2018

Translations of this European Technical Assessment in other languages shall fully correspond to the original issued document and should be identified as such.

Communication of this European Technical Assessment, including transmission by electronic means, shall be in full excepted the confidential Annex(es) referred to above. However, partial reproduction may be made, with the written consent of the issuing Technical Assessment Body. Any partial reproduction has to be identified as such.

II SPECIFIC PART OF THE EUROPEAN TECHNICAL ASSESSMENT

1 Technical description of the product

The SORMAT through bolt S-KA is an anchor made of galvanized steel (designated as S-KA). The SORMAT through bolt S-KAK is an anchor made of hot dip galvanized steel (designated as S-KAK). The SORMAT through bolt S-KAH is an anchor made of stainless steel (designated as S-KAH). The SORMAT through bolt S-KAH HCR is an anchor made of high corrosion resistant stainless steel (designated as S-KAH HCR). The anchors are made in sizes M8, M10, M12 and M16. Anchors are placed into a drilled hole and anchored by torque-controlled expansion.

2 Specification of the intended uses in accordance with the applicable European Assessment Document, EAD

2.1 Intended uses

The anchors are intended to be used for anchorages for which requirements for mechanical resistance and stability and safety in use in the sense of the Essential Requirements 1 and 4 of Council Directive 89/106/EEC shall be fulfilled and failure of anchorages made with these products would compromise the stability of the works, cause risk to human life and/or lead to considerable economic consequences.

The anchors may be used for anchorages with requirements related to resistance to fire.

The anchor is to be used only for anchorages subject to static or quasi-static loading in reinforced or unreinforced normal weight concrete of strength classes C 20/25 at minimum and C50/60 at the most according to EN 206: 2000-12. It may be anchored in cracked and non-cracked concrete.

The SORMAT S-KA and SORMAT S-KAK anchors may only be used in concrete subject to dry internal conditions.

The SORMAT S-KAH anchor may be used in structures subject to dry internal conditions and also in structures subject to external atmospheric exposure (including industrial and marine environments), or exposure in permanently damp internal conditions, if no particular aggressive conditions exist. Such particular aggressive conditions are e.g. permanent, alternating immersion in seawater or the splash zone of seawater, chloride atmosphere of indoor swimming pools or atmosphere with chemical pollution (e.g. road tunnels where de-icing materials are used).

The SORMAT S-KAH HCR anchor may be used in structures subject to dry internal conditions and also in structures subject to external atmospheric exposure, in permanently damp internal conditions or in other particular aggressive conditions. Such particular aggressive conditions are e.g. permanent, alternating immersion in seawater or the splash zone of seawater, chloride atmosphere of indoor swimming pools or atmosphere with chemical pollution (e.g. in desulphurization plants or road tunnels where de-icing materials are used).

2.2 Working life

The provisions made in this European Technical Assessment are based on an assumed intended working life of the anchor of 50 years.

The indications given on the working life cannot be interpreted as a guarantee given by the producer or assessment body, but are to be regarded only as a means for choosing the right products in relation to the expected economically reasonable working life of the works.

2.3 Installation

2.3.1. Design of anchorages

The fitness of the anchors for the intended use is given under the following conditions:

The anchorages are designed in accordance with the “Guideline for European Technical Approval of Metal Anchors for Use in Concrete”, Annex C, Method A, for torque controlled expansion anchors under the responsibility of an engineer experienced in anchorages and concrete work.

Verifiable calculation notes and drawings are prepared taking account of the loads to be anchored.

The position of the anchor is indicated on the design drawings (e.g. position of the anchor relative to reinforcement or to support, in cracked or non-cracked concrete, etc.).

The design of anchorages under fire exposure has to consider conditions given in Technical report TR 020 “Evaluation of anchorages in concrete concerning resistance to fire”. The relevant characteristic anchor values are given in the Annexes 7 and 8. The design method covers anchors with a fire attack from one side only. If the fire attack is from more than one side, the design method may be taken only, if the edge distance of the anchor is $c \geq 300$ mm.

2.3.2. Installation of anchors

The fitness for use of the anchor can only be assumed if the anchor is installed as follows:

- Anchor installation carried out by appropriately qualified personnel and under the supervision of the person responsible for technical matters on the site.
- Use of the anchor only as supplied by the manufacturer without exchanging the components of an anchor.
- Anchor installation in accordance with the manufacturer's specifications and drawings prepared for that purpose and using the appropriate tools.
- Thickness of the fixture corresponding to the range of required thickness value for the type of anchor
- Checks before placing the anchor to ensure that the strength class of the concrete in which the anchor is to be placed is in the range given and is not lower than that of the concrete to which the characteristic loads apply.
- Check of concrete being well compacted, e.g. without significant voids.
- Clearing the hole of drilling dust.
- Keeping of the edge distance and spacing to the specified values without minus tolerances.
- Positioning of the drill holes without damaging the reinforcement.
- In case of aborted hole: new drilling at a minimum distance away of twice the depth of the aborted hole or smaller distance if the aborted drill hole is filled

with high strength mortar and if under shear or oblique tension load it is not in the direction of load application.

- Application of the torque moment given in Annex 4 using a calibrated torque wrench.

2.3.3. Responsibility of the manufacturer

It is the manufacturer's responsibility to ensure that the information on the specific conditions according to 1 and 2 including Annexes referred to in 2.3.1 and 2.3.2 is given to those who are concerned. This information may be made by reproduction of the respective parts of the European Technical Approval. In addition all installation data shall be shown clearly on the package and/or on an enclosed instruction sheet, preferably using illustration(s).

The minimum data required are:

- drill bit diameter,
- thread diameter,
- maximum thickness of the fixture,
- minimum effective anchorage depth,
- minimum hole depth,
- required torque moment,
- information on the installation procedure, including cleaning of the hole, preferably by means of an illustration,
- reference to any special installation equipment needed,
- identification of the manufacturing batch.

All data shall be presented in a clear and explicit form.

3 Performance of the product and references to the methods used for its assessment

3.1 Characteristics of product

Mechanical resistance and stability (BWR1):

The essential characteristics are detailed in the Annex from 1 to 8.

Safety in case of fire (BWR2):

The essential characteristics are detailed in the Annex from 7 to 8.

Hygiene, health and the environment (BWR3):

Regarding the dangerous substances contained in this European Technical Assessment, there may be other requirements applicable to the products falling within its scope (e.g. transposed European legislation and national laws, regulations and administrative provisions). In order to meet the provisions of the Construction Products Regulation, these requirements need also to be complied with, when and where they apply.

Safety in use (BWR4):

For basic requirement Safety in use the same criteria are valid for Basic Requirement Mechanical resistance and stability (BWR1).

Protection against noise (BWR5):

Not relevant.

Energy economy and heat retention (BWR6):

Not relevant.

Sustainable use of natural resources (BWR7)

No performance determined.

3.2 Methods of assessment

The assessment of fitness of the anchor for the intended use in relation to the requirements for mechanical resistance and stability and safety in use in the sense of the Basic Requirements 1 and 4 has been made in accordance with the « Guideline for European Technical Approval of Metal Anchors for use in Concrete », Part 1 « Anchors in general » and Part 2 « Torque-controlled expansion anchors ».

4 Assessment and verification of constancy of performance (hereinafter AVCP)

According to the Decision 1999/454/EC of the European Commission¹, the system of assessment and verification of constancy of performance (see Annex V to the regulation (EU) No 305/2011) is 1.

Regarding the requirements concerning safety in case of fire it is assumed that the anchor meets the requirements A1 in relation to the reaction to fire in accordance with the stipulations in the Commission decision 96/582/EC L 254 8.10.1996.

The assessment of the anchors for the intended use in relation to the requirements for resistance to fire has been made in accordance with the Technical report TR 020 "Evaluation of anchorages in concrete concerning resistance to fire". The design of anchorages under fire exposure has to consider conditions given in Technical report TR 020 "Evaluation of anchorages in concrete concerning resistance to fire". The relevant characteristic anchor values are given in the Annexes 7 and 8. The design method covers anchors with a fire attack from one side only. If the fire attack is from more than one side, the design method may be taken only, if the edge distance of the anchor is $c \geq 300$ mm.

5 Technical details necessary for the implementation of the AVCP system, as provided for in the applicable EAD

Technical details necessary for the implementation of the AVCP system are laid down in the control plan deposited at VTT Expert Services Ltd.

Issued in Espoo on May 23, 2014
by VTT Expert Services Ltd

Tiina Ala-Outinen
Business Manager

Pertti Jokinen
Product Manager

Annexes 1-8, pages 7-14 of this ETA.

SORMAT through bolt

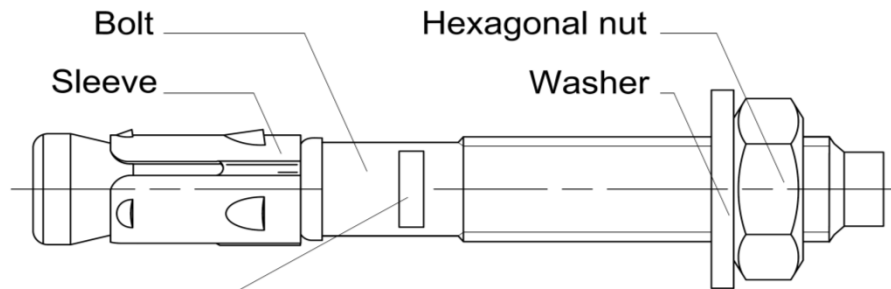

Marking:	Identifying mark:	S	
	Anchor identity:	KA	
	Category* ¹⁾ :	H (stainless steel)	
		K (hot dip galvanized)	
	Thread size:	M8 ... M16	
	Max. fixture thickness:	t_{fix}	
	Material* ¹⁾ :	HCR	
	Examples:	S-KA 10/20	- zinc plated
		S-KAK 10/20	- hot dip galvanized
		S-KAH 10/20	- stainless steel A4
		S-KAH 10/20 HCR	- stainless steel HCR

*¹⁾: Where applicable

SORMAT through bolt after installation

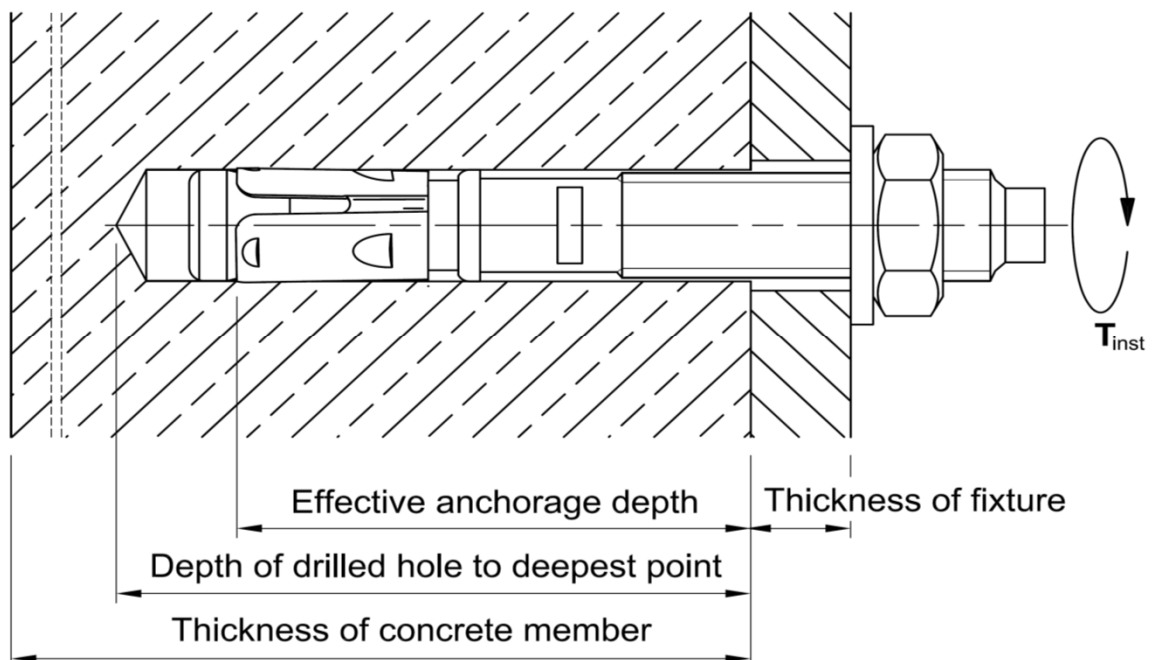

SORMAT through bolt

Product and intended use

Annex 1

of European
Technical Assessment
ETA - 08 / 0173

SORMAT through bolt

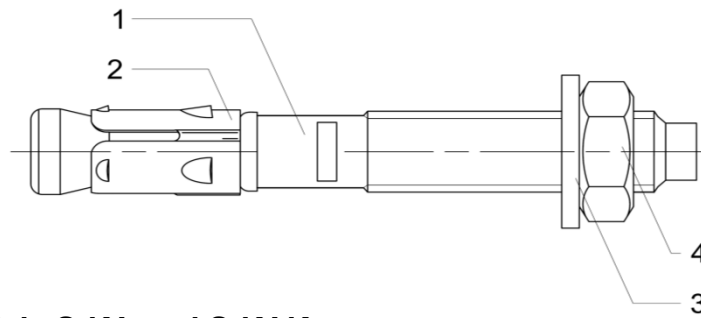

Table 1a: Materials S-KA and S-KAK

Part	Designation	Diameter	Material ^{1) 2)}	f_{yk} [N/mm ²]	f_{uk} [N/mm ²]
1	Bolt	M10 + M12	Cold forged steel, EN 10263-2	560	660
		M8 + M16		475	560
2	Sleeve	M8 - M16	Cold rolled galvanized steel strip, EN 10147		
3	Washer	M8 - M16	Electroplated steel, DIN 125 (EN ISO 7089), DIN 440 (EN ISO 7094), DIN 9021 (EN ISO 7093)		
4	Hexagonal Nut	M8 - M16	Steel, electroplated, property class 8, DIN 934 (EN ISO 4032)		

¹⁾ **S-KA:** Parts 1, 3 and 4 are zinc electroplated according to EN ISO 4042 $\geq 5\mu\text{m}$ and bright passivated.

²⁾ **S-KAK:** Parts 1, 3 and 4 are hot dip galvanized according to EN ISO 10684.

Table 1b: Materials S-KAH

Part	Designation	Diameters	Material	f_{yk} [N/mm ²]	f_{uk} [N/mm ²]
1	Bolt	M8 - M16	Cold forged stainless steel, EN 10088-3	530	600
2	Sleeve	M8 - M16	Stainless steel strip, EN 10088-2		
3	Washer	M8 - M16	Stainless steel, DIN 125 (EN ISO 7089), DIN 440 (EN ISO 7094), DIN 9021 (EN ISO 7093)		
4	Hexagonal Nut	M8 - M16	Stainless steel, property class 80, DIN 934 (EN ISO 4032)		

Table 1c: Materials S-KAH HCR

Part	Designation	Diameters	Material	f_{yk} [N/mm ²]	f_{uk} [N/mm ²]
1	Bolt	M8 - M16	Cold forged stainl. steel, EN 10088-3 1.4529 / 1.4565	530	600
2	Sleeve	M8 - M16	Stainless steel strip, EN 10088-2		
3	Washer	M8 - M16	Stainless steel, W 1.4529 / 1.4565, DIN 125 (EN ISO 7089), DIN 440 (EN ISO 7094), DIN 9021 (EN ISO 7093)		
4	Hexagonal Nut	M8 - M16	Stainless steel, property class 70, W 1.4529 / 1.4565 DIN 934 (EN ISO 4032)		

SORMAT through bolt

Materials

Annex 2

of European
Technical Assessment
ETA - 08 / 0173

SORMAT through bolt

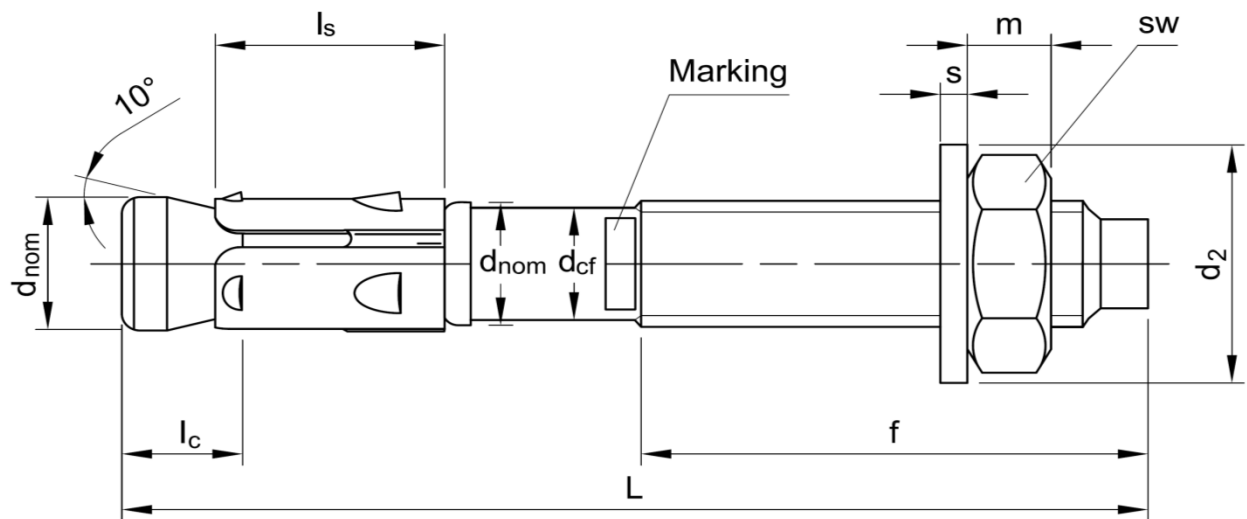

Table 2: Dimensions of the anchor

Main dimensions			Stud bolt		Cone bolt		Expansion sleeve	Washer			Hexagonal nut	
Anchor type	Size	L [mm]	f [mm]	d _{cf} [mm]	d _{nom} [mm]	l _c [mm]	l _s [mm]	s [mm]	d ₁ [mm]	d ₂ [mm]	sw [mm]	m [mm]
8 / 0.....358	M8	62...420	22...220	7,1	8	20,9	15,9	≥1,6	≥8,4	≥16	13	≥6,5
10 / 0.....338	M10	82...420	37...215	9,0	10	25,7	17,9	≥2,0	≥10,5	≥20	≥16	≥8,0
12 / 0.....322	M12	98...420	48...210	10,8	12	30,3	19,1	≥2,5	≥13,0	≥24	≥18	≥10,0
16 / 0.....302	M16	118...420	60...202	14,6	16	38,1	26,3	≥3,0	≥17,0	≥30	24	≥13,0

SORMAT through bolt

Dimensions of the anchor

Annex 3

of European
Technical Assessment
ETA - 08 / 0173

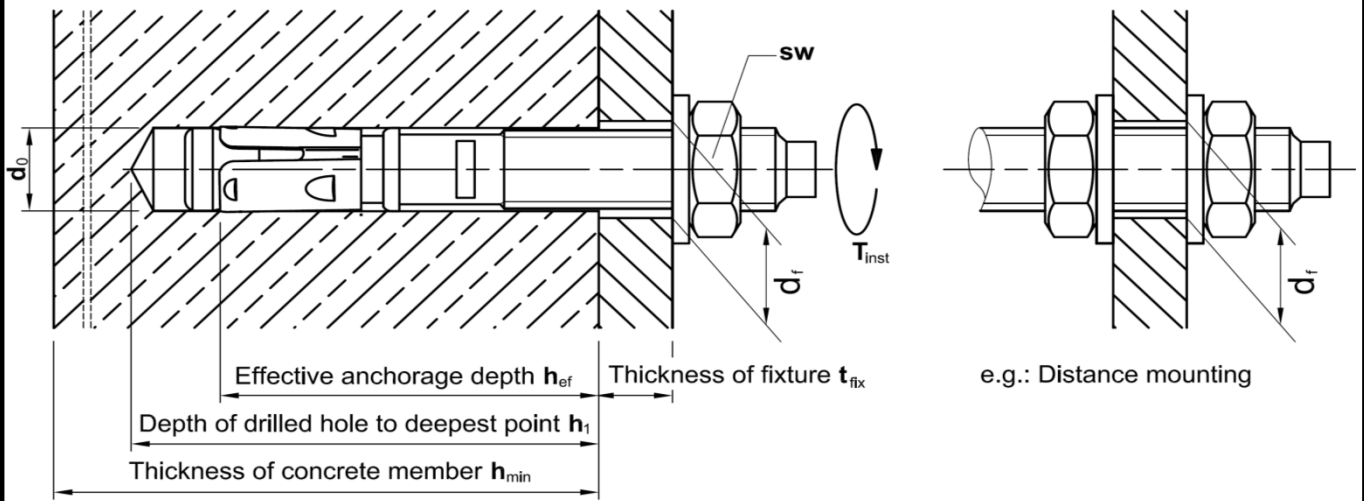

Table 3: Installation data

SORMAT through bolt		Anchor size			
		M8	M10	M12	M16
Drill hole diameter	d_0 [mm]	8	10	12	16
Cutting diameter at the upper tolerance limit (maximum diameter bit)	$d_{cut,max} \leq$ [mm]	8,45	10,45	12,5	16,5
Depth of drilled hole to deepest point	$h_1 \geq$ [mm]	60	75	90	110
Effective anchorage depth	h_{ef} [mm]	45	60	70	85
Diameter of clearance hole in the fixture	$d_f \leq$ [mm]	9	12	14	18
Thickness of fixture	$t_{fix,min...max}$ [mm]	0...358	0...338	0...322	0...302
Width across flats	SW [mm]	13	≥ 16	≥ 18	24
Required torque S-KA / S-KAK S-KAH / S-KAH HCR	T_{inst} [Nm]	20 / 15 ¹⁾	35	50	120
		20	35	70	120

¹⁾ Installation torque for S-KA is 20 Nm and for S-KAK 15 Nm

Table 4: Minimum thickness of concrete member, spacing and edge distance

SORMAT through bolt		Anchor size			
		M8	M10	M12	M16
Minimum thickness of concrete member	h_{min} [mm]	100	120	140	170
Minimum spacing	s_{min} [mm]	50	55	60	70
	$c \geq$ [mm]	50	80	90	120
Minimum edge distance	c_{min} [mm]	50	50	55	85
	$s \geq$ [mm]	50	100	145	150

Intervals may be interpolated linearly.

SORMAT through bolt	Annex 4 of European Technical Assessment ETA - 08 / 0173
Installation data, Minimum thickness of concrete member, Spacing and edge distance	

Table 5: Design method A - Characteristic values for tension loads

SORMAT through bolt			Anchor size			
			M8	M10	M12	M16
Steel failure						
Characteristic resistance S-KA / S-KAK	$N_{Rk,s}$	[kN]	13	26	38	69
Characteristic resistance S-KAH / S-KAH HCR	$N_{Rk,s}$	[kN]	15	24	35	75
Partial safety factor	$\gamma_{Ms}^{1)}$	[-]	1,40			
Pull-out failure						
Characteristic resistance in cracked concrete C20/25	$N_{Rk,p}$	[kN]	5	9	12	20
Characteristic resistance in non cracked concrete C20/25	$N_{Rk,p}$	[kN]	9	16	20	35
Increasing factor for $N_{Rk,p}$	Ψ_C	C25/30	1,04			
		C30/37	1,10			
		C35/45	1,16			
		C40/50	1,20			
		C45/55	1,24			
		C50/60	1,28			
Partial safety factor	$\gamma_{Mp}^{1)}$	[-]	1,80 ²⁾			1,50 ³⁾
Concrete cone failure						
Effective anchorage depth	h_{ef}	[mm]	45	60	70	85
Spacing	$s_{cr,N}$	[mm]	135	180	210	255
Edge distance	$c_{cr,N}$	[mm]	68	90	105	128
Partial safety factor	$\gamma_{Mc}^{1)}$	[-]	1,80 ²⁾			1,50 ³⁾
Concrete splitting failure						
Spacing (splitting)	$s_{cr,sp}$	[mm]	180	240	280	340
Edge distance (splitting)	$c_{cr,sp}$	[mm]	90	120	140	170
Partial safety factor	$\gamma_{Msp}^{1)}$	[-]	1,80 ²⁾			1,50 ³⁾

¹⁾ In absence of other national regulations.

²⁾ The installation safety factor of $\gamma_2 = 1,2$ is included.

³⁾ The installation safety factor of $\gamma_2 = 1,0$ is included.

Table 6: Displacements under tension loads

SORMAT through bolt			Anchor size			
			M8	M10	M12	M16
Cracked and non-cracked concrete C20/25 - C50/60	N	[kN]	2,0	3,6	4,8	9,5
	δ_{N0}	[mm]	0,3	0,6	0,6	0,7
	$\delta_{N\infty}$	[mm]	1,8	1,6	2,0	1,4

SORMAT through bolt

Design method A :
Characteristic values for tension loads and displacements

Annex 5

of European
Technical Assessment
ETA - 08 / 0173

Table 7: Design method A - Characteristic values for shear loads

SORMAT through bolt			Anchor size			
			M8	M10	M12	M16
Steel failure without lever arm						
Characteristic resistance S-KA / S-KAK	$V_{Rk,s}$	[kN]	10	18	23	44
Characteristic resistance S-KAH / S-KAH HCR	$V_{Rk,s}$	[kN]	11	17	25	47
Partial safety factor	$\gamma_{Ms}^{1)}$	[-]	1,50			
Steel failure with lever arm						
Characteristic resistance S-KA / S-KAK	$M_{Rk,s}^0$	[Nm]	21	48	72	186
Characteristic resistance S-KAH / S-KAH HCR	$M_{Rk,s}^0$	[Nm]	22	45	79	200
Partial safety factor	$\gamma_{Ms}^{1)}$	[-]	1,50			
Concrete pryout failure						
Factor in equation (5.6) of ETAG Annex C, § 5.2.3.3	k	[-]	1	2		
Partial safety factor	$\gamma_{Mc}^{1)}$	[-]	1,50			
Concrete edge failure						
Effective length of anchor under shear load	l_f	[mm]	45	60	70	85
Outside diameter of anchor	d_{nom}	[mm]	8	10	12	16
Cracked concrete without any edge reinforcement	$\Psi_{ucr,V}$	[-]	1,00			
Cracked concrete with straight edge reinforcement > Ø12 mm			1,20			
Cracked concrete with edge reinforcement and closely spaced stirrups ($a \leq 100\text{mm}$) or non cracked concrete			1,40			
Partial safety factor	$\gamma_{Mc}^{1)}$	[-]	1,50			

¹⁾ In absence of other national regulations.

Table 8: Displacements under shear loads

SORMAT through bolt			Anchor size			
			M8	M10	M12	M16
Cracked and non-cracked concrete C20/25 - C50/60	V	[kN]	5,7	10,3	13,1	25,1
	δ_{V0}	[mm]	1,7	1,7	2,4	3,2
	$\delta_{V\infty}$	[mm]	2,6	2,6	3,6	4,8

SORMAT through bolt

Design method A:
Characteristic values for shear loads and displacements

Annex 6

of European
Technical Assessment
ETA - 08 / 0173

Table 9: Design method A - Characteristic tension resistance in cracked and non-cracked C20/25 to C50/60 under fire exposure

SORMAT through bolt		Anchor size															
		M8				M10				M12				M16			
Fire resistance duration	R... [min]	30	60	90	120	30	60	90	120	30	60	90	120	30	60	90	120
Steel failure																	
Characteristic resistance $N_{Rk,s,fi}$ [kN]	S-KA / S-KAK	1,3	0,7	0,4	0,3	2,3	1,3	0,8	0,5	3,6	2,0	1,3	0,9	5,3	3,0	1,8	1,3
	S-KAH / S-KAH HCR	5,7	3,9	2,0	1,1	9,1	6,1	3,2	1,8	13,2	8,9	4,7	2,6	24,5	16,6	8,7	4,8
Pull-out failure																	
Characteristic resistance	$N_{Rk,p,fi}$ [kN]	1,3		1,0	2,3		1,8	3,0		2,4	5,0		4,0				
Concrete cone failure																	
Characteristic resistance	$N^0_{Rk,c,fi}$ [kN]	2,4		2,0	5,0		4,0	7,4		5,9	12,0		9,6				
Spacing	$s_{cr,N}$ [mm]	4 x h_{ef}															
	s_{min} [mm]	50				55				60				70			
Edge distance	$c_{cr,N}$ [mm]	2 x h_{ef}															
	c_{min} [mm]	Fire attack from one side:								$c_{min} = 2 \times h_{ef}$							
		Fire attack from more than one side:								$c_{min} \geq 300 \text{ mm}$							

In absence of other national regulations the partial safety factor for resistance under fire exposure $\gamma_{M,fi} = 1,0$ is recommended.

SORMAT through bolt

Annex 7

Characteristic values of tension load resistance under fire exposure

of European Technical Assessment
ETA - 08 / 0173

Characteristic values of shear load resistance
under fire exposure**SORMAT through bolt****Annex 8**of European
Technical Assessment
ETA - 08 / 0173**Table 10: Design method A - Characteristic shear resistance in cracked and non-cracked C20/25 to C50/60 under fire exposure**

SORMAT through bolt		Anchor size																															
		M8				M10				M12				M16																			
Fire resistance duration	R... [min]	30	60	90	120	30	60	90	120	30	60	90	120	30	60	90	120																
Steel failure without lever arm																																	
Characteristic resistance $V_{Rk,s,fi}$ [kN]	S-KA / S-KAK	1,3	0,7	0,4	0,3	2,3	1,3	0,8	0,5	3,6	2,0	1,3	0,9	5,3	3,0	1,8	1,3																
	S-KAH / S-KAH HCR	5,7	3,9	2,0	1,1	9,1	6,1	3,2	1,8	13,2	8,9	4,7	2,6	24,5	16,6	8,7	4,8																
Steel failure with lever arm																																	
Characteristic resistance $M^0_{Rk,s,fi}$ [Nm]	S-KA / S-KAK	1,8	1,3	0,8	0,6	3,6	2,6	1,6	1,1	6,4	4,6	2,8	1,9	16,2	11,7	7,2	4,9																
	S-KAH / S-KAH HCR	5,8	4,0	2,1	1,1	11,7	7,9	4,2	2,3	20,4	13,9	7,3	4,0	52,0	35,2	18,5	10,2																
Concrete pryout failure																																	
Factor in equation (5.6) of ETAG 001 Annex C, 5.2.3.3	k [-]	1,0				2,0				2,0				2,0																			
Characteristic resistance	$V^0_{Rk,cp,fi}$ [kN]	2,4				2,0				10,0				8,0				14,8				11,8				24,0				19,2			
Concrete edge failure																																	
<p>The initial value $V^0_{Rk,c,fi}$ of the characteristic resistance in concrete C20/25 to C50/60 under fire exposure may be determined by:</p> $V^0_{Rk,c,fi} = 0,25 \times V^0_{Rk,c} \quad (\leq R90) \quad V^0_{Rk,c,fi} = 0,20 \times V^0_{Rk,c} \quad (R120)$ <p>with $V^0_{Rk,c}$ initial value of the characteristic resistance in cracked concrete C20/25 under normal temperature.</p>																																	

In absence of other national regulations the partial safety factor for resistance under fire exposure $\gamma_{M,fi} = 1,0$ is recommended.