

Approval body for construction products  
and types of construction

Bautechnisches Prüfamt

An institution established by the Federal and  
Laender Governments



## European Technical Assessment

**ETA-04/0072**  
**of 25 August 2014**

### General Part

Technical Assessment Body issuing the  
European Technical Assessment:

Deutsches Institut für Bautechnik

Trade name of the construction product

K-A-L-M Injection Mortar VMK-SF

Product family  
to which the construction product belongs

Bonded anchor for use in non-cracked concrete

Manufacturer

KALM  
Befestigungssysteme GmbH  
Marie-Curie-Straße 5  
67661 Kaiserslautern  
DEUTSCHLAND

Manufacturing plant

KALM  
Befestigungssysteme GmbH  
Marie-Curie-Straße 5  
67661 Kaiserslautern

This European Technical Assessment  
contains

10 pages including 3 annexes which form an integral part  
of this assessment

This European Technical Assessment is  
issued in accordance with Regulation (EU)  
No 305/2011, on the basis of

Guideline for European technical approval of "Metal  
anchors for use in concrete", ETAG 001 Part 5: "Bonded  
anchors", April 2013,  
used as European Assessment Document (EAD)  
according to Article 66 Paragraph 3 of Regulation (EU)  
No 305/2011.

The European Technical Assessment is issued by the Technical Assessment Body in its official language. Translations of this European Technical Assessment in other languages shall fully correspond to the original issued document and shall be identified as such.

Communication of this European Technical Assessment, including transmission by electronic means, shall be in full. However, partial reproduction may only be made with the written consent of the issuing Technical Assessment Body. Any partial reproduction has to be identified as such.

This European Technical Assessment may be withdrawn by the issuing Technical Assessment Body, in particular pursuant to information by the Commission according to Article 25 Paragraph 3 of Regulation (EU) No 305/2011.

**Specific Part**

**1 Technical description of the product**

The KALM Injection Mortar VMK-SF is a bonded anchor consisting of a mortar cartridge with injection Mortar VMK-SF, and a steel element. The steel element consist of a threaded rod ASK with washer and hexagon nut in the range of M10, M12 and M16. The steel element are made of galvanised steel, stainless steel or high corrosion resistant steel.

The steel element is placed into a drilled hole filled with injection mortar and is anchored via the bond between metal part, injection mortar and concrete.

The product description is given in Annex A.

**2 Specification of the intended use in accordance with the applicable European Assessment Document**

The performances given in Section 3 are only valid if the anchor is used in compliance with the specifications and conditions given in Annex B.

The verifications and assessment methods on which this European Technical Assessment is based lead to the assumption of a working life of the anchor of at least 50 years. The indications given on the working life cannot be interpreted as a guarantee given by the producer, but are to be regarded only as a means for choosing the right products in relation to the expected economically reasonable working life of the works.

**3 Performance of the product and references to the methods used for its assessment**

**3.1 Mechanical resistance and stability (BWR 1)**

Essential characteristic	Performance
Characteristic Values for all load directions	See Annex C 1

**3.2 Safety in case of fire (BWR 2)**

Essential characteristic	Performance
Reaction to fire	Anchorage satisfy requirements for Class A1
Resistance to fire	No performance determined (NPD)

**3.3 Hygiene, health and the environment (BWR 3)**

Regarding dangerous substances there may be requirements (e.g. transposed European legislation and national laws, regulations and administrative provisions) applicable to the products falling within the scope of this European Technical Assessment. In order to meet the provisions of Regulation (EU) No 305/2011, these requirements need also to be complied with, when and where they apply.

**3.4 Safety in use (BWR 4)**

The essential characteristics regarding Safety in use are included under the Basic Works Requirement Mechanical resistance and stability.

**3.5 Protection against noise (BWR 5)**

Not applicable.

**3.6 Energy economy and heat retention (BWR 6)**

Not applicable.

**3.7 Sustainable use of natural resources (BWR 7)**

The sustainable use of natural resources was not investigated.

**3.8 General aspects**

The verification of durability is part of testing the essential characteristics. Durability is only ensured if the specifications of intended use according to Annex B are taken into account.

**4 Assessment and verification of constancy of performance (AVCP) system applied, with reference to its legal base**

According to Decision of the Commission of 24 June 1996 (96/582/EC) (OJ L 254 of 08.10.96 p. 62-65), the system of assessment and verification of constancy of performance (see Annex V and Article 65 Paragraph 2 to Regulation (EU) No 305/2011) given in the following table applies.

Product	Intended use	Level or class	System
Metal anchors for use in concrete (heavy-duty type)	For fixing and/or supporting concrete structural elements or heavy units such as cladding and suspended ceilings	—	1

**5 Technical details necessary for the implementation of the AVCP system, as provided for in the applicable European Assessment Document**

Technical details necessary for the implementation of the AVCP system are laid down in the control plan deposited at Deutsches Institut für Bautechnik.

Issued in Berlin on 25 August 2014 by Deutsches Institut für Bautechnik

Uwe Bender  
Head of Department

*beglaubigt:*  
Baderschneider

### Installation anchor

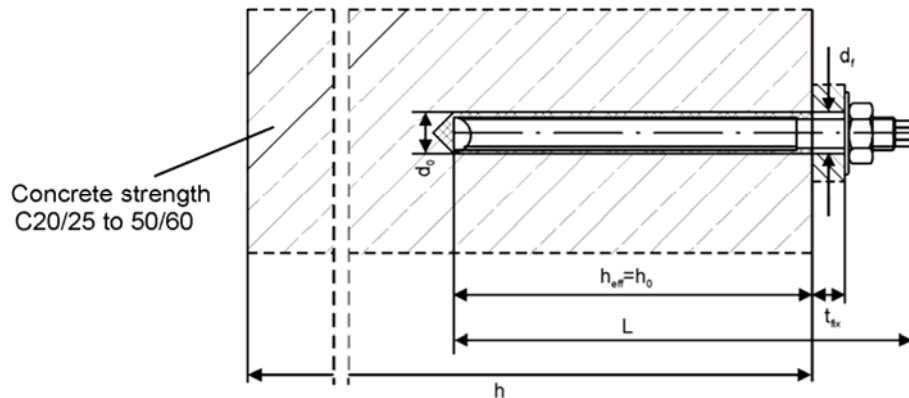

### Threaded rod ASK

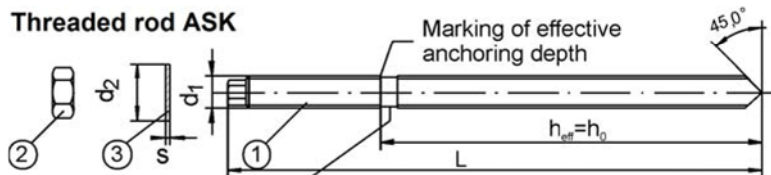

### Marking 1

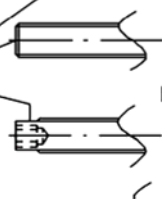

Marking1: Identifying mark of manufacturing plant K  
Size of thread M...  
Example KM10, for stainless steel plus E,  
for high corrosion plus H

Marking2: Example:  , for stainless steel plus E,  
for high corrosion plus H

### Marking 2



Commercial standard threaded rod with:

- Materials, dimensions and mechanical properties according to Table A1 and A2
- Inspection certificate 3.1 according to EN 10204:2004
- Marking of embedment depth

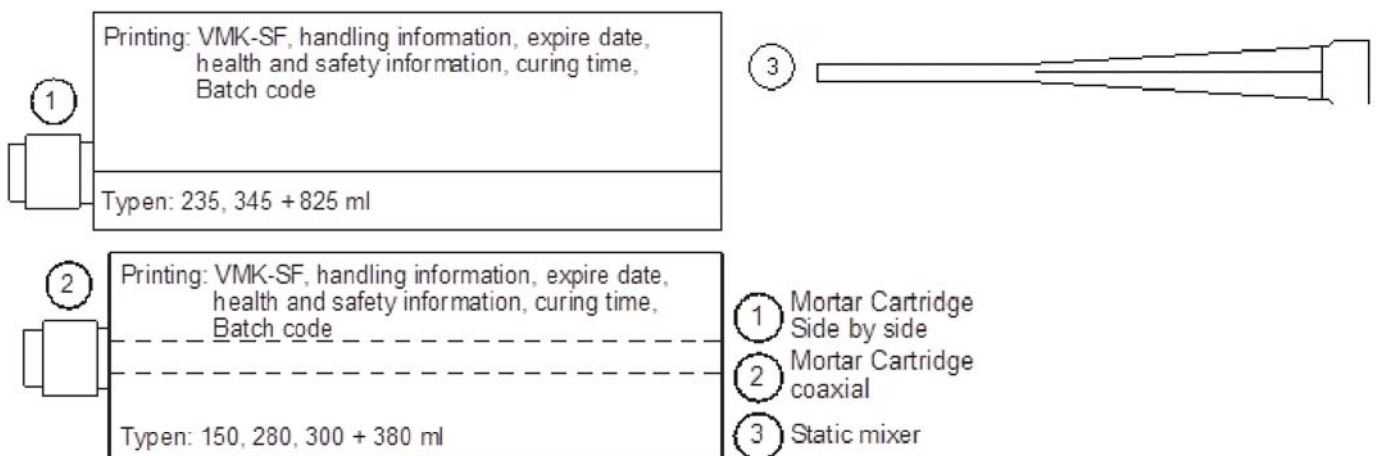

### K-A-L-M bonded anchor VMK-SF

#### Product description

Installed condition  
Threaded rod, Mortar Cartridge

Annex A 1

**Table A1: Dimensions of the anchor rod**

Anchor Sizes			M10	M12	M16
Diameter	$\varnothing d_1$	[mm]	M10	M12	M16
Length	$L \geq$	[mm]	100	120	140
Effective embedment depth	$h_{ef}$	[mm]	90	110	125

**Table A2: Materials**

Part	Designation	Materials	
		Steel, zinc plated $\geq 5 \mu\text{m}$ acc. to EN ISO 4042:1999	Steel, hot-dip galvanised $\geq 40 \mu\text{m}$ acc. to EN ISO 1461:2009
1	Threaded rod	Steel EN 10087:1998, EN 10263:2001 Property class 5.8, acc. to EN 1993-1-8:2005+AC:2009	
2	Hexagon Nut EN ISO 4032:2012	Steel EN 10087:1998, EN 10263:2001 Property class 8, acc. to EN ISO 898-2:2012	
3	Washer EN ISO 7089:2000 EN ISO 7093:2000 EN ISO 7094:2000	Steel, zinc plated	Steel, hot-dip galvanised
Part	Designation	Materials	
		Stainless steel A4	High corrosion resistant steel (HCR)
1	Threaded rod	Material 1.4401, 1.4404, 1.4571, 1.4578, EN 10088:2005, Property class 70, EN ISO 3506-1:2009	Material 1.4529, 1.4565, EN 10088:2005, Property class 70, EN ISO 3506-1:2009
2	Hexagon Nut EN ISO 4032:2012	Material 1.4401, 1.4404, 1.4571, EN 10088:2005, Property class 70, EN ISO 3506-2:2009	Material 1.4529, 1.4565, EN 10088:2005, Property class 70, EN ISO 3506-2:2009
3	Washer EN ISO 7089:2000 EN ISO 7093:2000 EN ISO 7094:2000	Material 1.4401, 1.4404, 1.4571, EN 10088:2005	Material 1.4529, 1.4565, EN 10088:2005
Part	Designation	Material	
4	Chemical mortar	Additive: quartz sand, Bonding agent: vinylester-resin, styrene free, Hardener: dibenzoyl peroxid	

**K-A-L-M bonded anchor VMK-SF**

**Product description**  
Dimensions  
Materials

**Annex A 2**

## Specifications of intended use

### Anchorage subject to:

- Static and quasi-static loads: all sizes.

### Base materials:

- Reinforced or unreinforced normal weight concrete according to EN 206-1:2000.
- Strength classes C20/25 to C50/60 according to EN 206-1:2000.
- Non-cracked concrete only: all sizes.

### Temperature Range:

- -40°C to 80°C (max. long term temperature +50 °C und max. short term temperature +80 °C)

### Use conditions (Environmental conditions):

- Structures subject to dry internal conditions (zinc coated steel, stainless steel or high corrosion resistant steel).
- Structures subject to external atmospheric exposure (including industrial and marine environment) and to permanently damp internal condition, if no particular aggressive conditions exist (stainless steel or high corrosion resistant steel).
- Structures subject to external atmospheric exposure and to permanently damp internal condition, if other particular aggressive conditions exist (high corrosion resistant steel).

Note: Particular aggressive conditions are e.g. permanent, alternating immersion in seawater or the splash zone of seawater, chloride atmosphere of indoor swimming pools or atmosphere with extreme chemical pollution (e.g. in desulphurization plants or road tunnels where de-icing materials are used).

### Design:

- Verifiable calculation notes and drawings are prepared taking account of the loads to be anchored. The position of the anchor is indicated on the design drawings (e. g. position of the anchor relative to reinforcement or to supports, etc.).
- Anchorages are designed under the responsibility of an engineer experienced in anchorages and concrete work.
- Anchorages are designed in accordance with ETAG 001, Annex C, Design Method C, Edition August 2010.

### Installation:

- Dry or wet concrete: all sizes.
- Hole drilling by hammer-drilling or compressed air drilling.
- During installation and curing of the chemical mortar the anchor component installation temperature shall be at least 0°C; the temperature of the concrete must not fall below -5 °C. Observe the curing time according to Table B2 until the anchor may be loaded.
- Anchor installation carried out by appropriately qualified personnel and under the supervision of the person responsible for technical matters of the site.

<b>K-A-L-M bonded anchor VMK-SF</b>	<b>Annex B 1</b>
<b>Intended Use Specifications</b>	

**Table B1: Installation Parameter**

Anchor Sizes			M10	M12	M16
Nominal drill hole diameter	$d_0$	[mm]	12	14	18
Cutting diameter of drill hole	$d_{cut} \leq$	[mm]	12,45	14,5	18,5
Depth of drill hole	$h_0 \geq$	[mm]	90	110	125
Effective embedment depth	$h_{ef}$	[mm]	90	110	125
Diameter of clearance hole in the fixture	$d_f \leq$	[mm]	12	14	18
Diameter of steel brush	$d$	[mm]	13	16	20
Installation torque Moment	$T_{inst}$	[Nm]	20	40	60
Maximum thickness of the fixture	$t_{fix}$	[mm]	1400	1380	1360
Minimum thickness of member	$h_{min}$	[mm]	130	160	160
Minimum edge distance	$c_{min}$	[mm]	180	220	250
Minimum spacing	$s_{min}$	[mm]	180	220	250

### Cleaning Tools

#### Steel Brush



#### Blow Pump ABK



**Table B2: Minimum curing times**

Concrete Temperature [°C]	Minimum curing time in dry concrete [min]	Minimum curing time in wet concrete [min]
-5°C to 0°C	360	720
0°C to 5°C	180	360
5°C to 20°C	90	180
20°C to 30°C	45	90
30°C to 40°C	25	50
> 40°C	15	30

**K-A-L-M bonded anchor VMK-SF**

**Intended Use**

Installation Parameter, Cleaning Tools  
Minimum curing times

**Annex B 2**



## Installation Instruktion

- Drill the hole: Use a percussion drill.
- Cleaning of the drillhole:  
twice in each case with the brush DBK  
with the Blowpump ABK and again with the brush  
DBK. \*(with hollow blocks introduce the sleeve SHK).
- Insert the mortar cartridge into the injection gun APK.  
Reject the first 10 cm strand or the first two strokes.
- Fill in the mortar from the drill-hole-deepest (sleeve-  
deepest).
- Rotate the fixing element ASK, ASK-E or ASK-H  
into the hole.
- Let the mortar harden (see reaction times).
- Fasten the element and tight the nut  
(see Technical data)

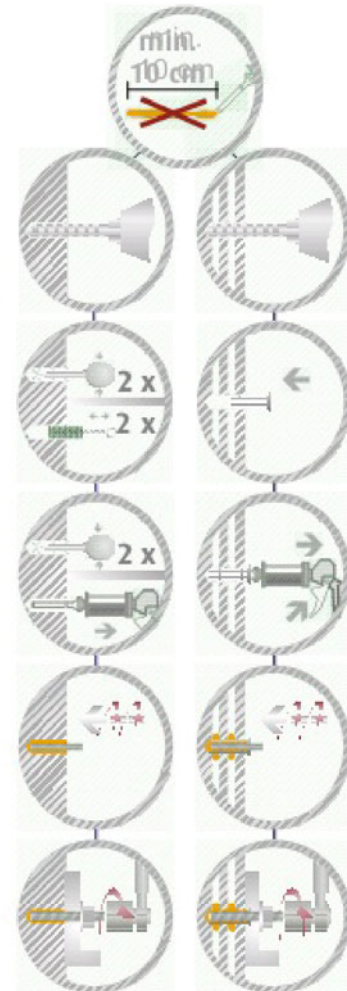

K-A-L-M bonded anchor VMK-SF

Intended Use  
Installation instruction

Annex B 3

**Table C1: Characteristic Values**

Anchor Sizes			M10	M12	M16
<b>For all load directions</b>					
Design Value in C20/25 to C50/60	$F_{Rd}$	[kN]	7,7	13,9	16,7
Edge Distance	$c_{cr}$	[mm]	180	220	250
Spacing	$s_{cr}$	[mm]	180	220	250
<b>Shear loads with lever arm for strenght class 5.8</b>					
Characteristic Bending Moment	$M^0_{Rk,s}$ <sup>2)</sup>	[Nm]	30	56	133
<b>Shear loads with lever arm for strenght class 70</b>					
Characteristic Bending Moment	$M^0_{Rk,s}$ <sup>2)</sup>	[Nm]	40	75	194

<sup>2)</sup> Characteristic Bending Moment  $M^0_{Rk,s}$  for Equation 5.5 in ETAG 001, Annex C

**Table C2: Displacements**

Anchor Sizes			M 10	M 12	M 16
Load		[kN]	4,5	8,2	10,0
Displacement under short-term load	$\delta_0$	[mm]	0,9	1,2	0,9
Displacements under long-term load	$\delta_{\infty}$	[mm]	2,0	2,0	2,0

**K-A-L-M bonded anchor VMK-SF**

Performances  
Characteristic Values  
Displacements

**Annex C 1**